

**ecoHITCH** -Designed Specifically For Your **Green Vehicle**

# Installation Instructions

Application Fits  
2015+ Subaru Outback  
X7266 & X7267

2" & 1.25" EcoHitch Stealth  
350 lbs. Tongue Weight/3,500 lbs Towing Weight

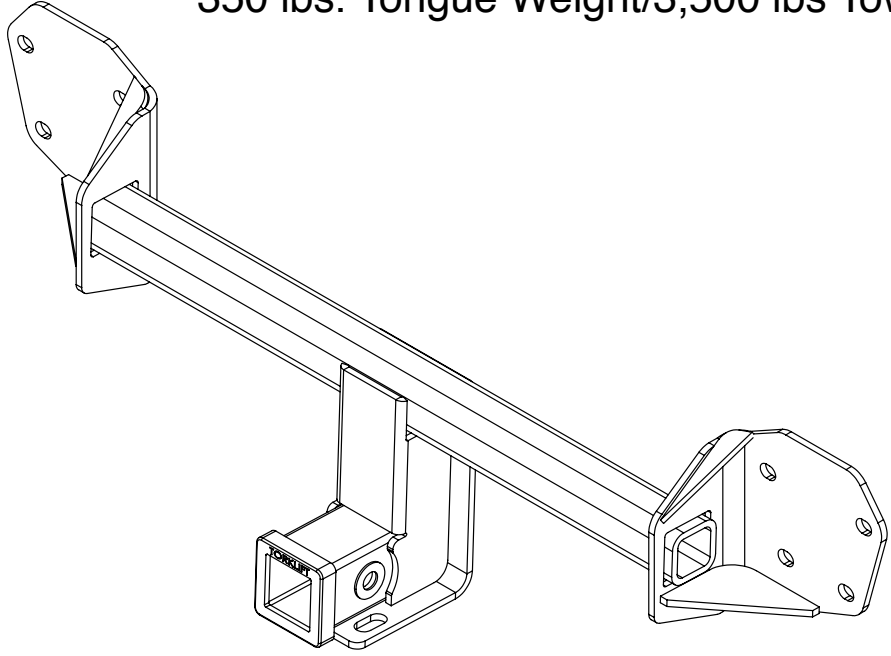

Torklift Central  
315 Central Ave N  
Kent, WA 98032  
253-854-1832  
[www.torkliftcentral.com](http://www.torkliftcentral.com)  
[support@tlcentral.com](mailto:support@tlcentral.com)

## Stay Connected



*Bolt Kit Weight: 113g +/-*

*Hardware Included*

QTY Fastener

8 M10 -1.25 Serrated Nuts

1 18" Trim-Lok

**READ THESE INSTRUCTIONS THOROUGHLY BEFORE BEGINNING INSTALLATION!**

**Step 1.** Raise vehicle on suitable jack stands or hoist.

**Step 2.** Open rear hatch to access tail light covers on driver and passenger sides.

**Step 3.** Remove tail light cover (driver and passenger sides) by removing screw clips (#1). See figure [1].

**Step 4.** Using a 10mm socket, remove two bolts (#2) to remove tail light assembly. Remove the assembly by pulling straight back. Repeat for both sides. See figure [1].

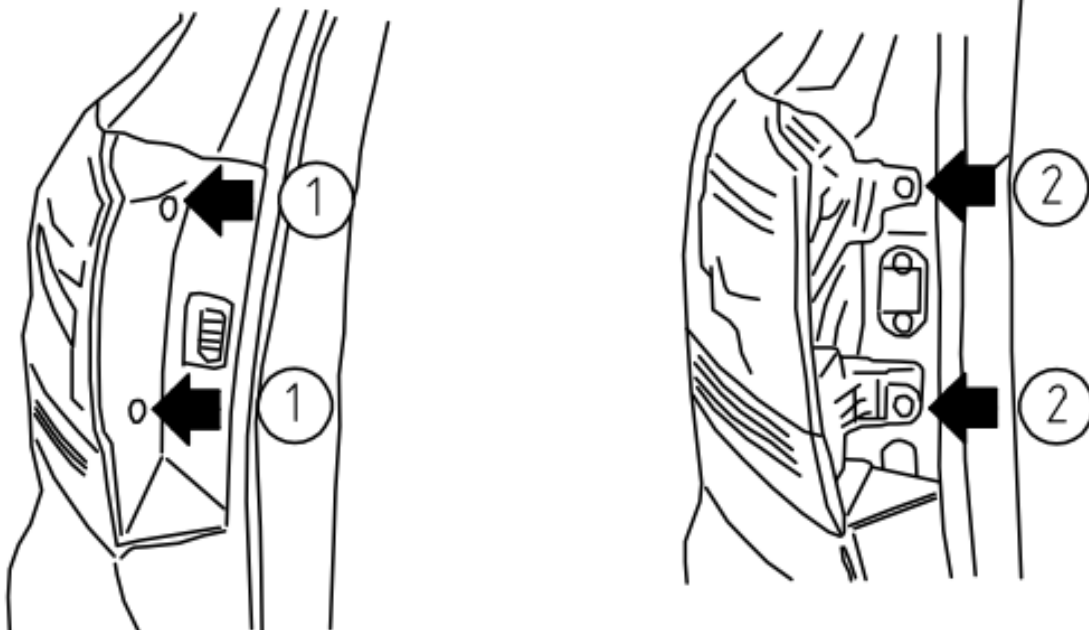

fig. [1]

**Step 5.** Remove screws (#3) from bumper fascia by opening covers. Repeat for both sides. See figure [2].

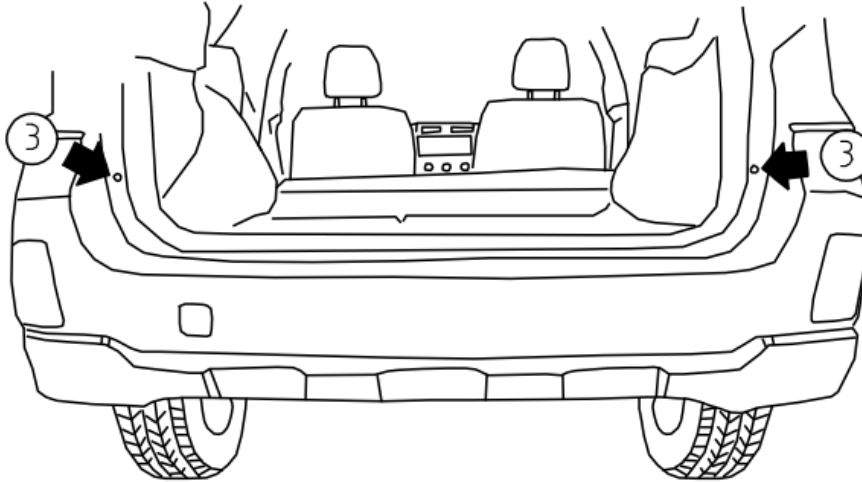

fig. [2]

**Step 6.** Remove tail light bulbs and connector (#4) from each side. Set parts aside for reinstallation later. See figure [3].

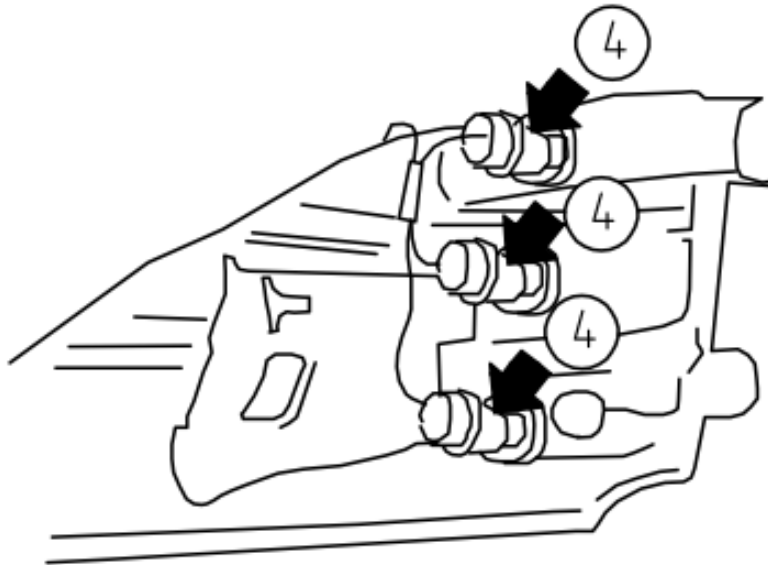

fig. [3]

**Step 7.** With a screwdriver, release small push button fastener (#1) per side on the left and right side of the fascia wheel well. Use the tip of the screwdriver to push the center of the pin in. See figure [4], Step 7.

**NOTE:** Some Outback models have splash guards in the wheel wells that must be removed before the bumper fascia can be removed. These are usually held in by screws or push pin clips.

**Step 8.** Using a flathead screwdriver, remove the seven large push pin clips (#2) along the underside of the bumper and set aside for reinstallation later. See figure [4], Step 8.

**Step 9.** Starting at the driver side rear wheel, using both hands, pull one side of the fascia out from the vehicle. Continue around the rear driver side. At the rear corner, begin to pull rearward and work across the vehicle from left to right to remove the entire bumper. The assistance of another person can be helpful but is not necessary. See figure [4], Step 9.

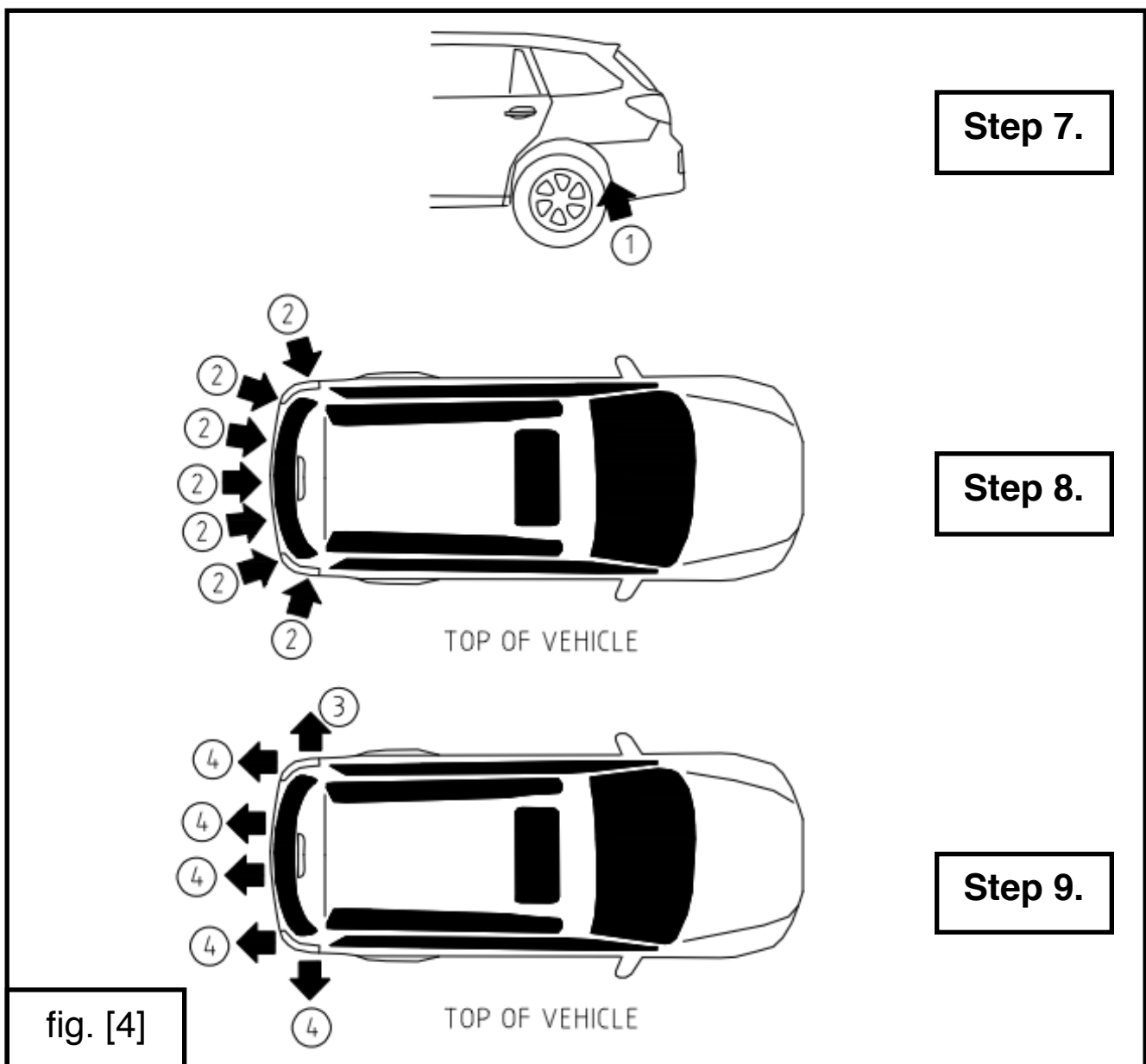

**Step 10.** Fully release the bumper from the vehicle body and lay fascia aside where it will not be damaged during hitch installation.

**Step 11.** With the bumper fascia removed, remove foam piece and discard. Remove bumper beam nuts from the stud bolts on the end of the frame. The top bolts can be accessed through tooling holes in bumper beam. Discard nuts.  
**Note:** Hold the bumper beam with one hand while taking off the last nut so it does not fall in the process. See figure [5].

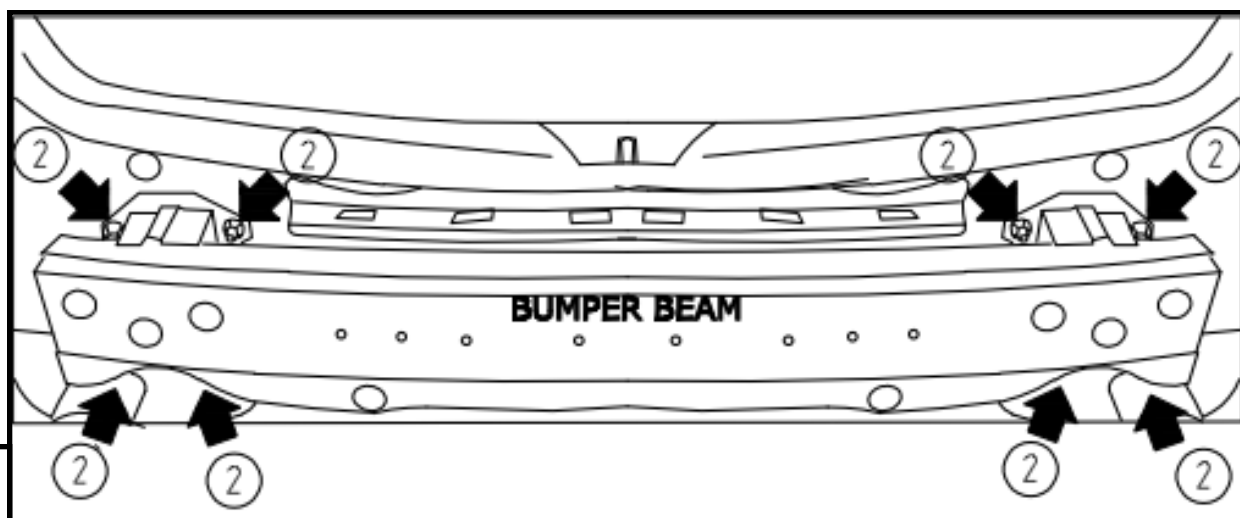

fig. [5]

**Step 12.** Bend the center metal tab up and then place the hitch onto the eight stud bolts on the vehicle (Figure [6]), then place the bumper beam over the hitch onto the studs. Loosely secure both components with the supplied M10 x 1.25 serrated nuts. Once centered on studs, torque nuts to 50ft lbs. See figure [7].



fig. [6]





fig. [7]

**Step 13.** On the inside of the bumper fascia, find the center of the bumper fascia and mark out a 5"x5"x7" box as shown in figure [8] and trim the bumper using an air saw or utility knife. This will allow the hitch receiver to sit close to the bumper fascia and ease reinstallation of the bumper fascia. See figure [8].

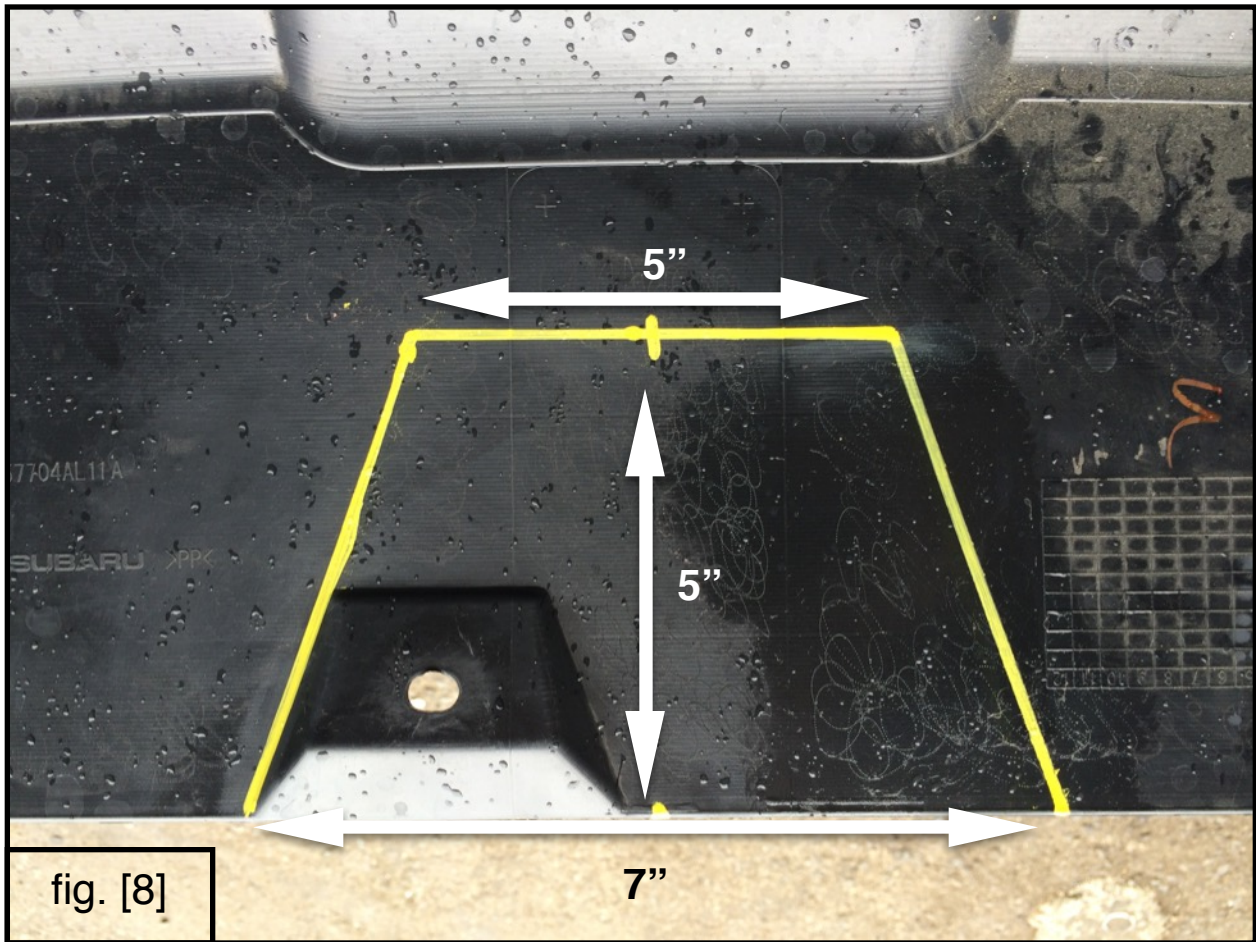

fig. [8]

**Step 14.** Attach the supplied Trim-Lok around the trimmed portion of the bumper fascia. Cut Trim-Lok to fit and discard excess.

**Step 15.** Reinstall bumper fascia and lighting assemblies by working backwards from Step 10.

**Congratulations on the successful installation of your EcoHitch for the  
2015+ Subaru Outback!**

It is designed with a lifetime warranty for a lifetime of enjoyment. If you have any questions or suggestions please contact us by email at [support@tlcentral.com](mailto:support@tlcentral.com) or by phone at (253)-854-1832





# WARRANTY/DISCLAIMER INFORMATION

Torklift Central requires proof of purchase for warranty claim registration, with pictures of any defective product before issuing a replacement. Torklift will not accept claims on any product without proof of purchase, which can be faxed, scanned, emailed or mailed to the information provided below. Torklift Central warrants its hitches, custom hitch receivers and accessories (excluding electrical wire harnesses which carry a warranty from their specified manufacturer) from date of purchase against defects in material and workmanship under normal use and service for the ownership life of the original consumer purchaser. Torklift Central will replace free of charge any part that proves defective in material or workmanship when presented to Torklift Central, transportation charges prepaid by purchaser, at the address below. **This warranty is limited to defective parts replacement only. Labor charges and/or damage incurred in installation or replacement, as well as incidental and consequential damages connected therewith are excluded.** This warranty does not include normal wear and tear or the finish and paint. Rusting, cracking or peeling of the finish is also excluded. Some states do not allow the exclusion or limitation of incidental or consequential damages, so the above limitation or exclusion may not apply to you. Any damage to Torklift Central products as a result of misuse, abuse, neglect, accident, improper installation or any use violative of instructions furnished by Torklift Central will void the warranty. This warranty gives you specific legal rights and you may also have rights, which vary from state to state. With warranty service, you may be able to go to a small claims court, a state court or a federal district court.

Although Torklift Central trailer hitches are both tested and rated for towing within the specific capacity label found on each trailer hitch. Torklift Central assumes no liability for vehicle manufacturers warranty due to the use of a Torklift Central trailer hitch being used for towing behind any vehicle or using the trailer hitch in a manner that it was not designed for. Although this specific trailer hitch has a load rating, which includes trailer tongue weight, and a trailer weight carrying capacity, Torklift Central is not responsible for the voiding of any warranty on any vehicle due to factory towing limitations. All vehicle warranties are the sole property and responsibility of the owner of the vehicle that the Torklift Central trailer hitch is installed upon. Torklift Central does not endorse towing behind any vehicle if the vehicles manufacturer states that towing is not recommended. Check your vehicle's owner's manual for the proper tow rating of your vehicle.

**ADDRESS:** 315 Central Ave N. Kent, WA 98032

**\*WARNING\*** Your vehicle may have a lower tow rating than this trailer hitch. If your vehicle's tow rating is less than the rated towing capacity on your Torklift Central trailer hitch, your trailer hitch capacity is limited to your vehicle's factory rated towing capacity.

**FOR EXAMPLE:** the label on your Torklift Central trailer hitch states it's capacity is rated for 500 pounds tongue weight and 5,000 pounds towing weight. However your vehicle's factory rated towing capacity is limited to only 350 pounds tongue weight and 3,500 pounds towing weight. In this example your maximum towing capacity of your Torklift Central trailer hitch is limited to 350 pounds tongue weight and 3,500 pounds towing weight as stated by your vehicle's maximum factory tow rating.

**\*DANGER\*** Never exceed your vehicle's manufacturer's recommended towing capacity which may be a lower rating than this trailer hitch

Unsure of your tow rating? Download our towing app from the app store to find your vehicles tow rating.  
[www.torkliftcentral.com/app.php](http://www.torkliftcentral.com/app.php)